



General Certificate of Secondary Education
2023

Centre Number

--	--	--	--	--

Candidate Number

--	--	--	--

Physics

Unit 2

Higher Tier

MV18

[GPY22]

FRIDAY 16 JUNE, MORNING

Time

1 hour 30 minutes, plus your additional time allowance.

Instructions to Candidates

Write your Centre Number and Candidate Number in the spaces provided at the top of this page.

You must answer the questions in the spaces provided.

Do not write on blank pages.

Complete in black ink only.

Answer **all five** questions.

Information for Candidates

The total mark for this paper is 100.

Figures in brackets printed at the end of each question indicate the marks awarded to each question or part question.

Quality of written communication will be assessed in

Question **4(a)**.

- 1 (a) A transverse wave created on a string is represented by the two graphs shown below. Use the graphs to answer the following questions.

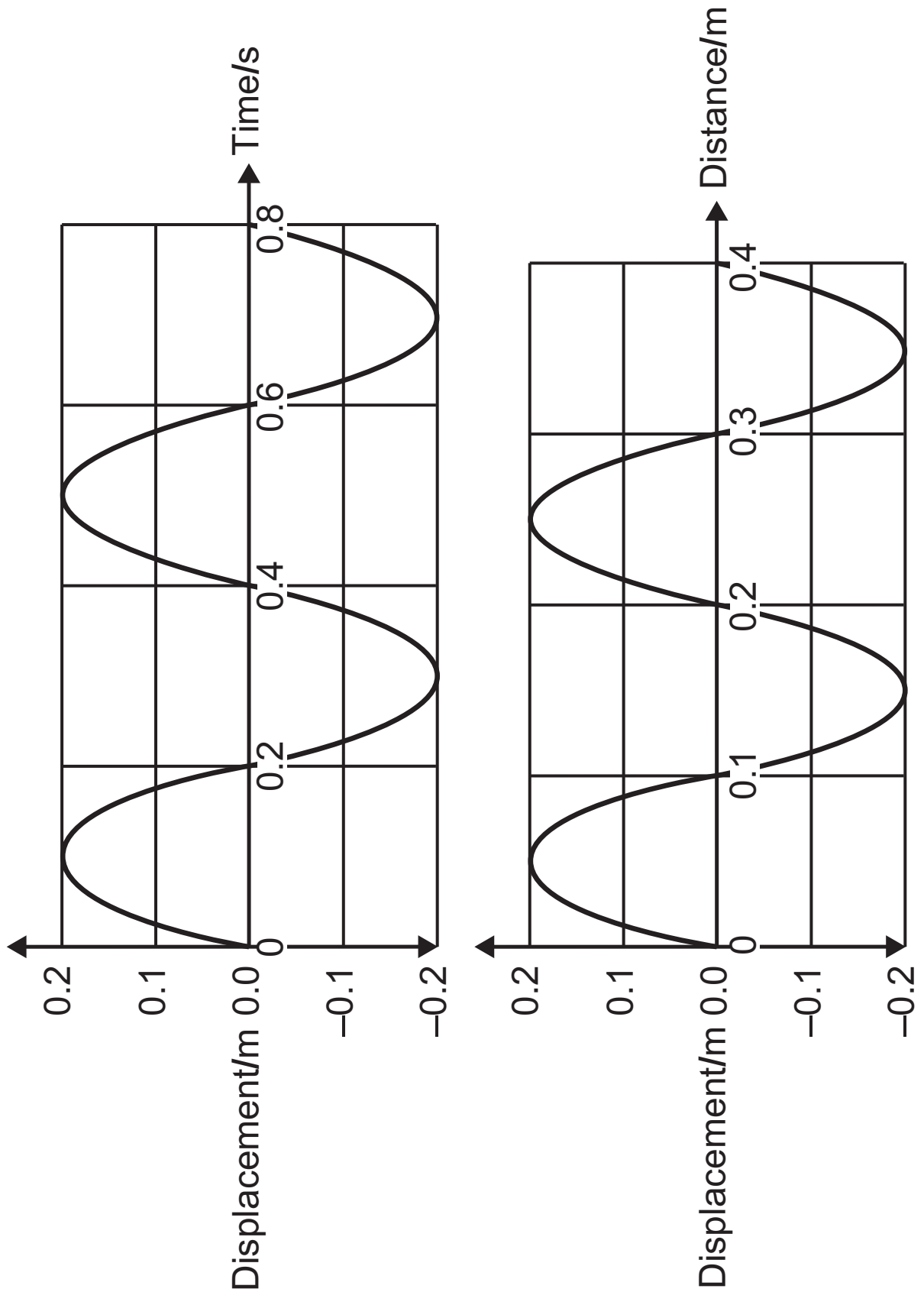

- (i) What is the wavelength of the wave shown?
[1 mark]

_____ m

- (ii) Calculate the frequency of the wave. [3 marks]
Include the unit for frequency with your answer.
Show clearly how you get your answer.

Frequency = _____

Unit = _____

- (iii) Using your values from (i) and (ii), calculate the velocity of the wave. [3 marks]
Show clearly how you get your answer, starting with the equation you plan to use.

Velocity = _____ m/s

(b) The diagram shows a water wave travelling in deep water and in shallow water.

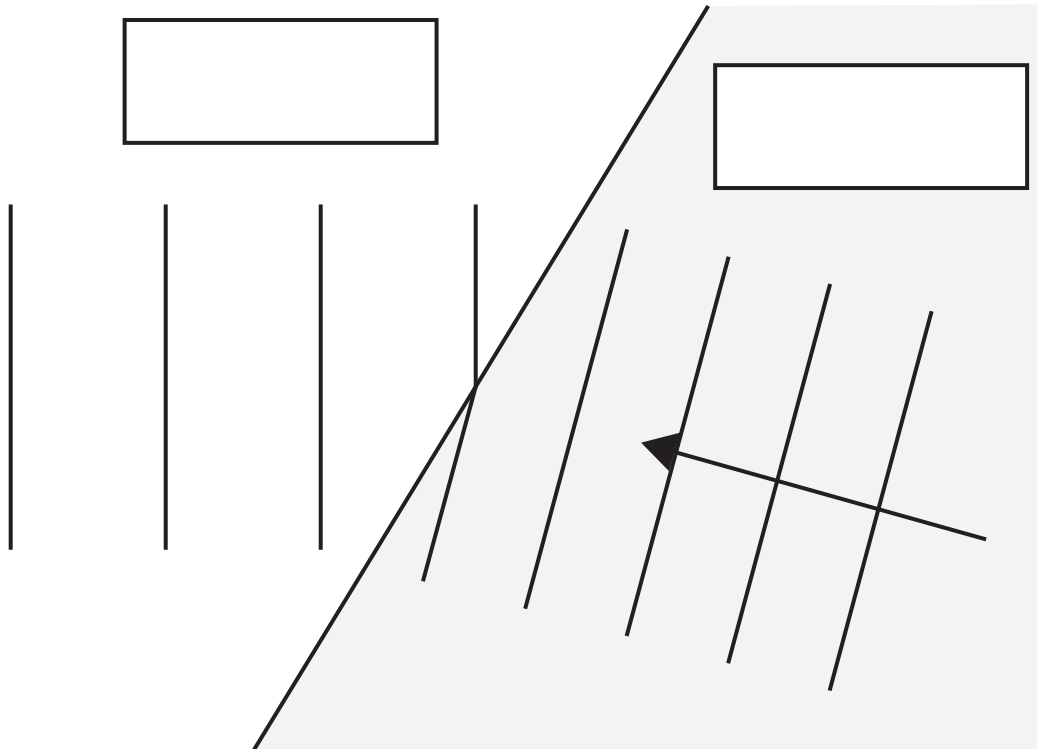

(i) Label the deep water and the shallow water.
Write the names in the boxes. [1 mark]

(ii) Explain how you arrived at your answer. [1 mark]

(c) (i) What is ultrasound? [1 mark]

Ultrasound can be used to detect a crack in large pieces of metal such as part of a railway track as shown below. The ultrasound is reflected from the various parts of the rail.

These reflections show up on the oscilloscope as pulses **A**, **B** and **C**.

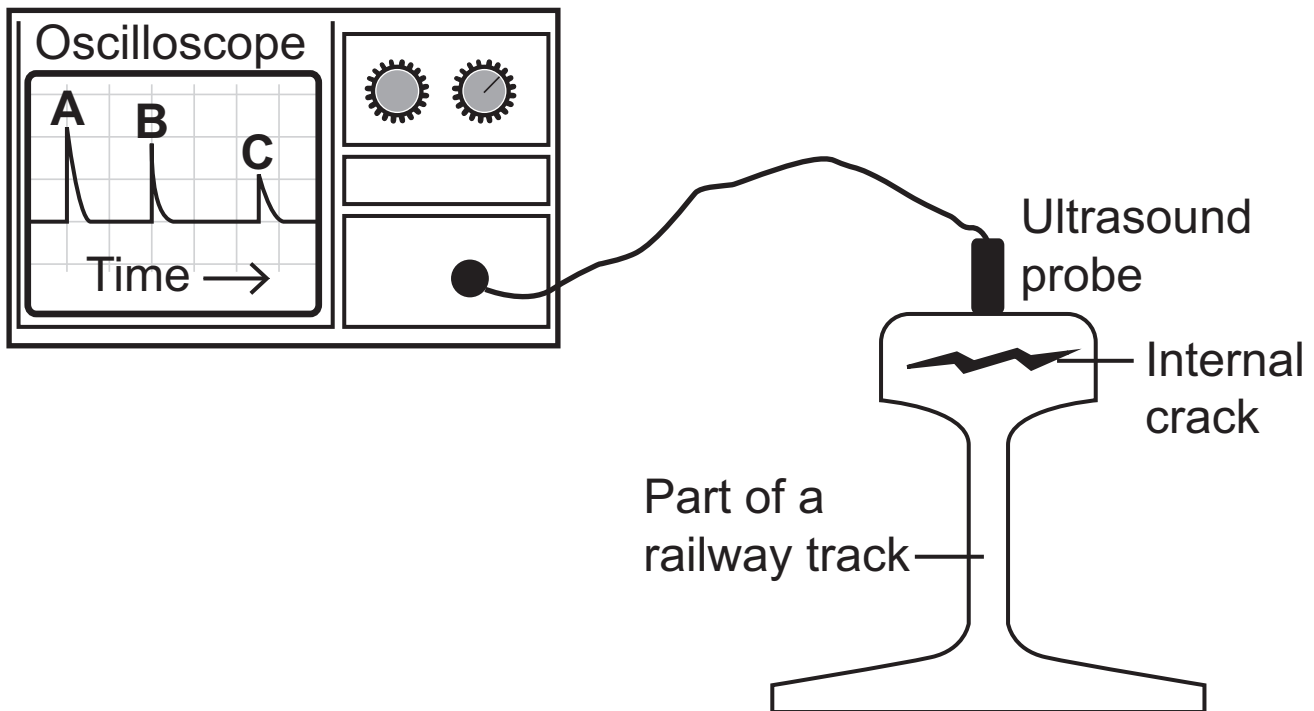

(ii) State the cause of the reflections **A**, **B** and **C**. [1 mark]

- (iii) The speed of ultrasound in steel is 5900 m/s.
Using the information shown in the diagram below,
calculate the distance between the top of the railway
track and the crack. [4 marks]
**Show clearly how you get your answer, starting
with the equation you plan to use.**

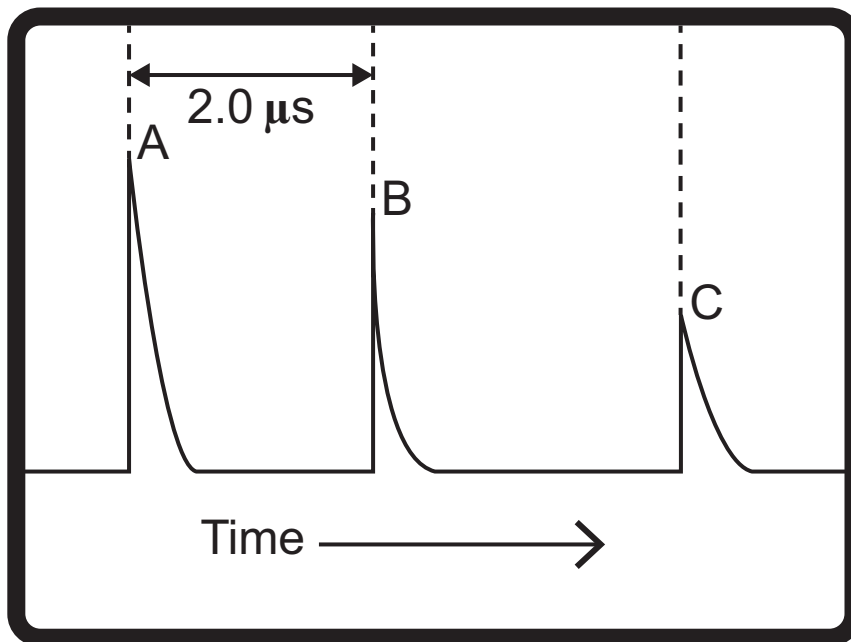

$$1 \mu\text{s} = 1 \text{ microsecond} = 1.0 \times 10^{-6} \text{ s}$$

Distance = _____ m

(d) Complete the diagram below by writing the various regions of the electromagnetic spectrum in the appropriate boxes. Place them in order of increasing wavelength. [3 marks]

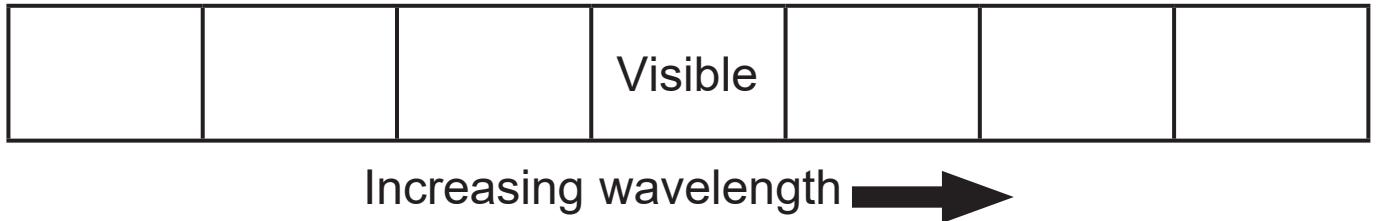

(e) Electromagnetic waves travel at the speed of light. Name **two** properties that make electromagnetic waves different from sound waves. [2 marks]

1. _____

2. _____

2 (a) When white light passes through a glass prism it is split into its component colours. This is known as dispersion.

(i) Complete the diagram below to show the paths taken by the red light and violet light through and out of the prism. Label each colour. [4 marks]

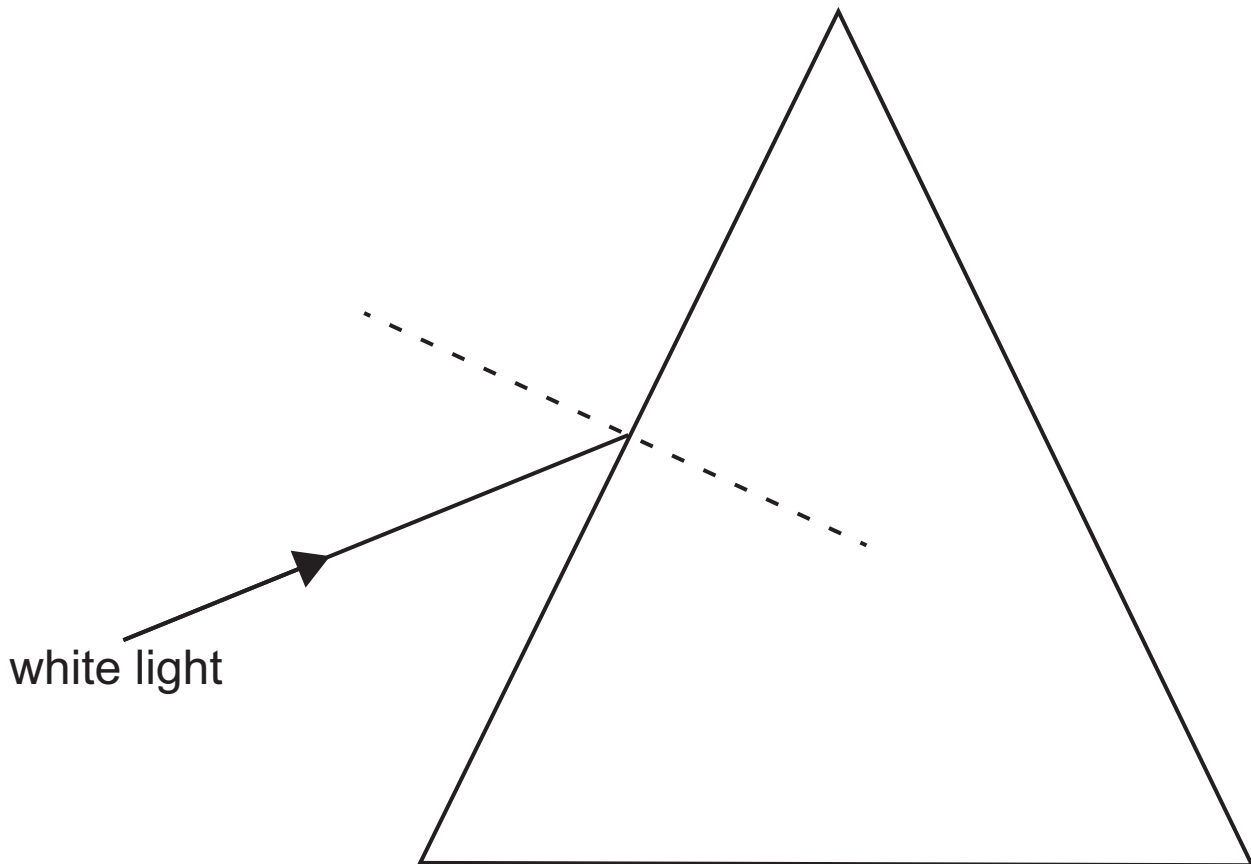

(ii) Explain fully why different colours are refracted by different amounts when they enter the glass prism. [2 marks]

(b) (i) What **two** conditions are needed before total internal reflection happens? [2 marks]

1. _____

2. _____

(ii) On the diagram below, draw **carefully** the path of the incident ray of light through the two right angled glass prisms until it emerges. [2 marks]

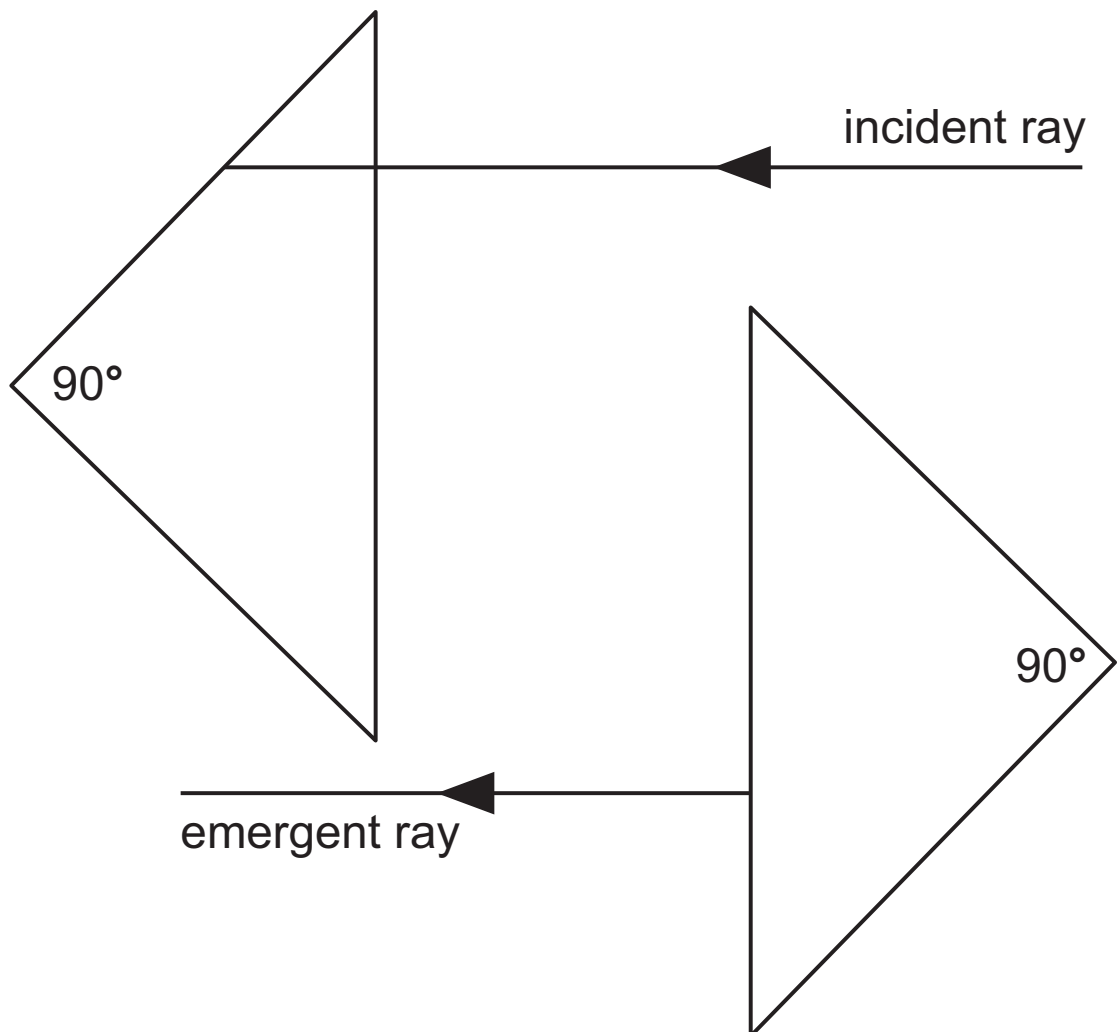

(c) The ray diagram for a converging lens shown below is incomplete.

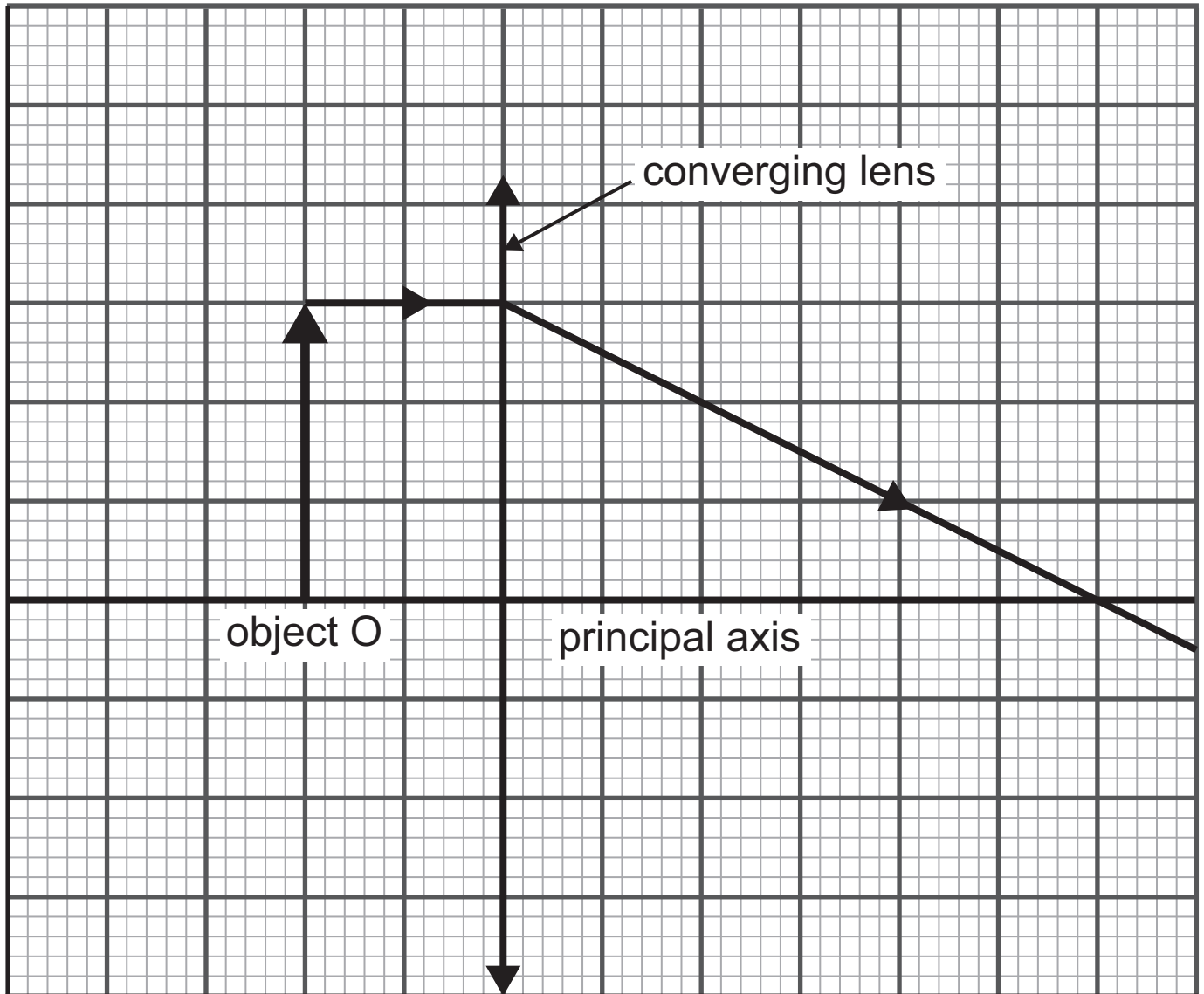

(i) On the diagram mark with a letter **F** the focal point (principal focus) of the lens. [1 mark]

(ii) Draw another ray and use it and the ray shown to locate the image.

Place an arrow on this ray.

Draw the image and label it **I**. [4 marks]

(iii) List **two** of the properties of this image. [2 marks]

(d) To measure the focal length of a converging lens, a student placed the lens in front of a screen and used it to obtain the image of a distant tree on the screen.

distant tree



converging lens

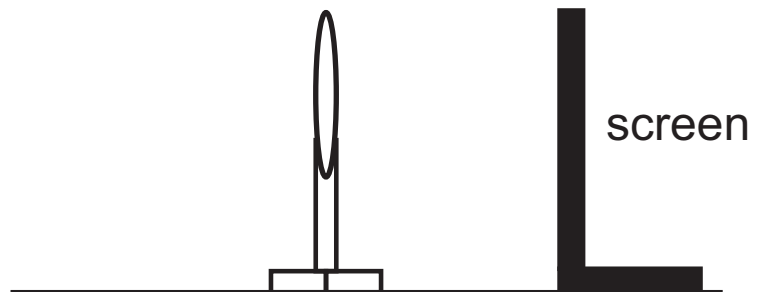

(i) How will the student know when the lens is in the correct position to allow the focal length to be measured? [1 mark]

(ii) What distance should be measured to obtain the focal length? [1 mark]

(iii) What should the student do to obtain a reliable value for the focal length? [2 marks]

(e) A person who is short-sighted is unable to see distant objects sharply.

(i) This problem is corrected by using a lens as shown in the diagram below.

Name the type of lens used. [1 mark]

(ii) Complete the diagram below to show how two parallel rays of light from a distant object pass through the diverging lens, the person's eye and reach the retina. [3 marks]

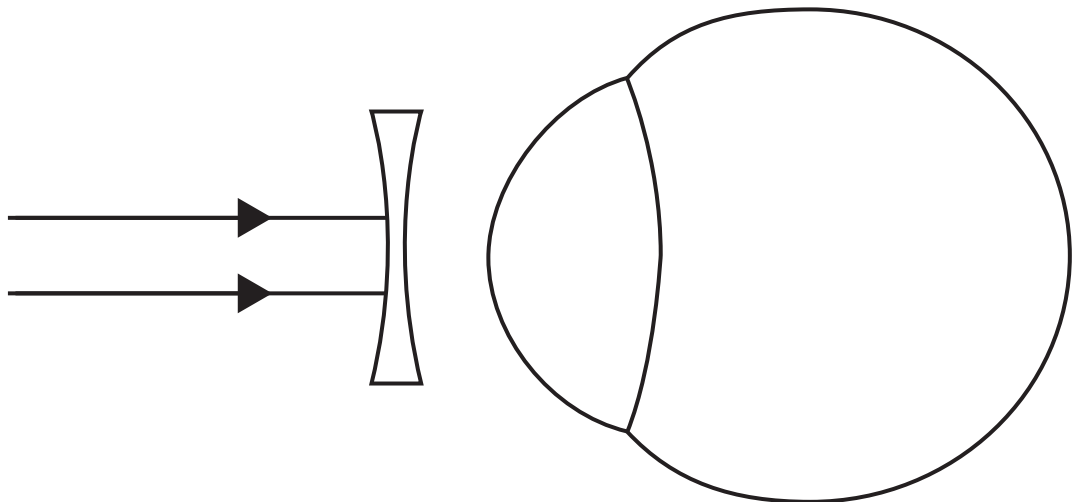

- 3 (a) (i) Calculate the total resistance of the circuit shown below. [3 marks]
Show clearly how you get your answer.

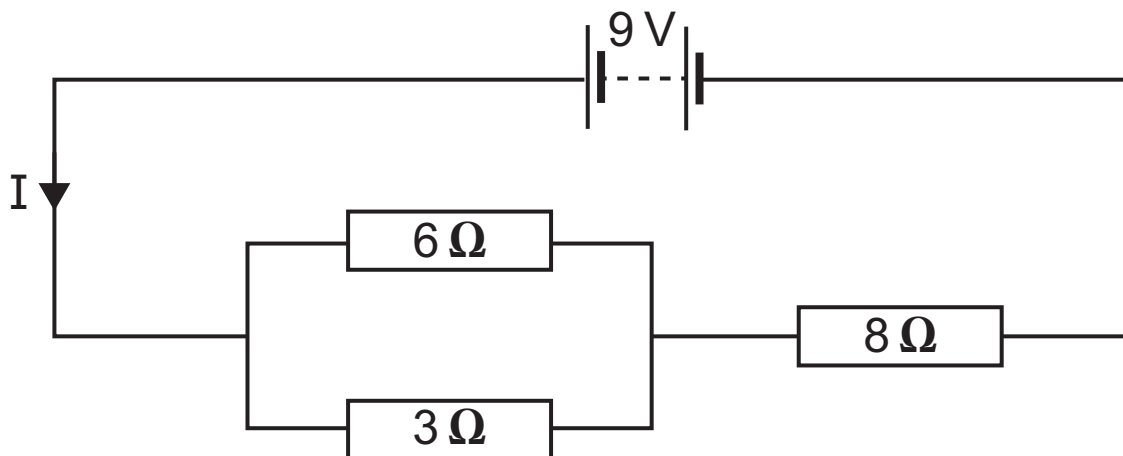

Resistance = _____ Ω

- (ii) Calculate the current marked **I**. [3 marks]
Show clearly how you get your answer, starting with the equation you plan to use.

Current = _____ A

- (iii) Calculate the voltage across the 8Ω resistor. [2 marks]
Show clearly how you get your answer.

Voltage = _____ V

(iv) Calculate the current through 6Ω resistor.

[2 marks]

Show clearly how you get your answer.

Current = _____ A

(b) To investigate how the resistance of a metal wire depends on its area of cross-section, a meter was used to measure the resistance of 10 cm lengths of wire of different cross-sectional areas.

The results are shown in the table.

Area of cross-section/ mm^2	Resistance/ Ω
1.0	1.60
2.0	0.85
3.0	0.55
4.0	0.40
5.0	1.35

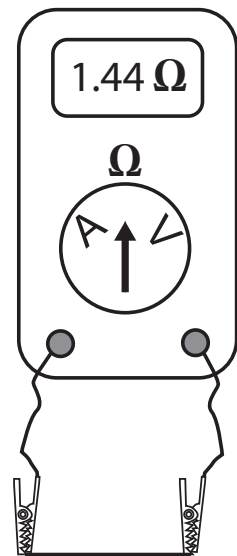

(i) One measurement is clearly anomalous.
Circle the anomalous measurement. [1 mark]

(ii) Why is it important to use wires of the same length during this investigation? [1 mark]

(iii) The relationship between resistance R and the area of cross-section A is shown below. In this equation k is a constant.

$$R = \frac{k}{A}$$

Explain how the results support this relationship.
[1 mark]

(iv) Using values from the table, find the value of the constant k . [4 marks]
Include the unit for k with your answer.
Show clearly how you get your answer.

$k =$ _____

Units of $k =$ _____

- (c) A household dishwasher has the following information on a label attached to it.

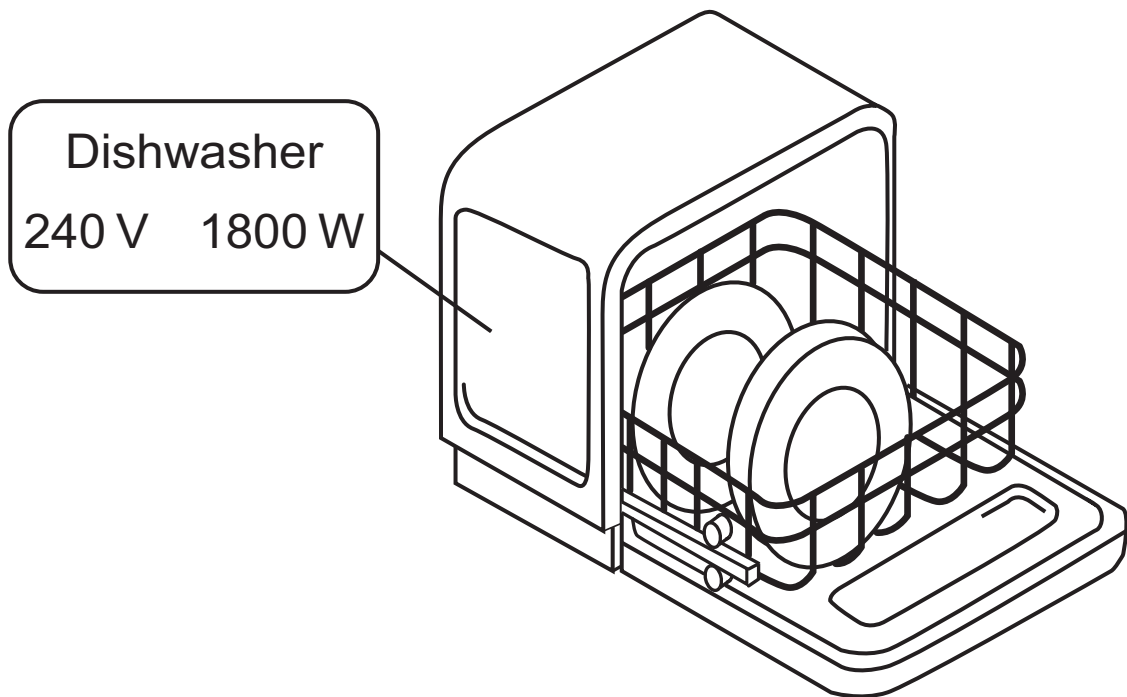

- (i) Choose a suitable fuse rating for the plug attached to it. [4 marks]
The range of fuses available is, 2A, 3A, 5A and 13A.
Show clearly how you get your answer, starting with the equation you plan to use.

Suitable fuse rating = _____ A

(ii) A unit of electricity costs 19p.

Calculate the cost of using the dishwasher for 120 minutes. [3 marks]

Show clearly how you get your answer, starting with the equation you plan to use.

Cost = _____ p

Blank Page

(Questions continue overleaf)

- 4 (a) Two coils of wire are wrapped around a soft iron core. One coil is connected to a cell and a switch. The other coil is connected to a centre-zero ammeter.

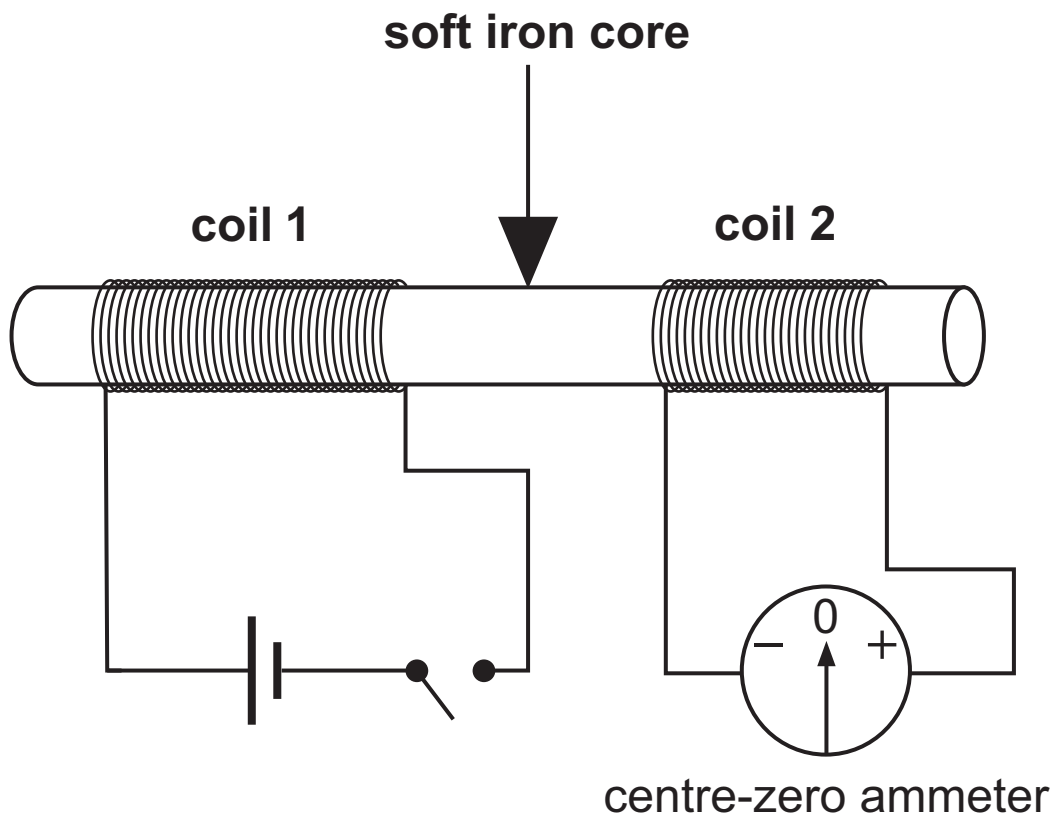

Describe how this apparatus is used to investigate electromagnetic induction. [6 marks]

In your description you should state:

- what is meant by electromagnetic induction, in the context of this experiment
- the purpose of the soft iron core
- what is observed on the centre-zero ammeter when the switch is closed and left closed

- what is observed on the centre-zero ammeter when the switch is reopened
- what device used in the transmission of electricity is based on the apparatus shown above.

In this question, you will be assessed on your written communication skills including the use of specialist scientific terms.

Write your answers in the appropriate space on the page below.

What is electromagnetic induction?

Purpose of the soft iron core

What is observed when the switch is closed and left closed?

What is observed when the switch is re-opened?

Device used in electricity transmission

(b) The diagram below shows a mobile phone connected to its charger.

The charger converts the mains voltage of 230V a.c. to 5V a.c.

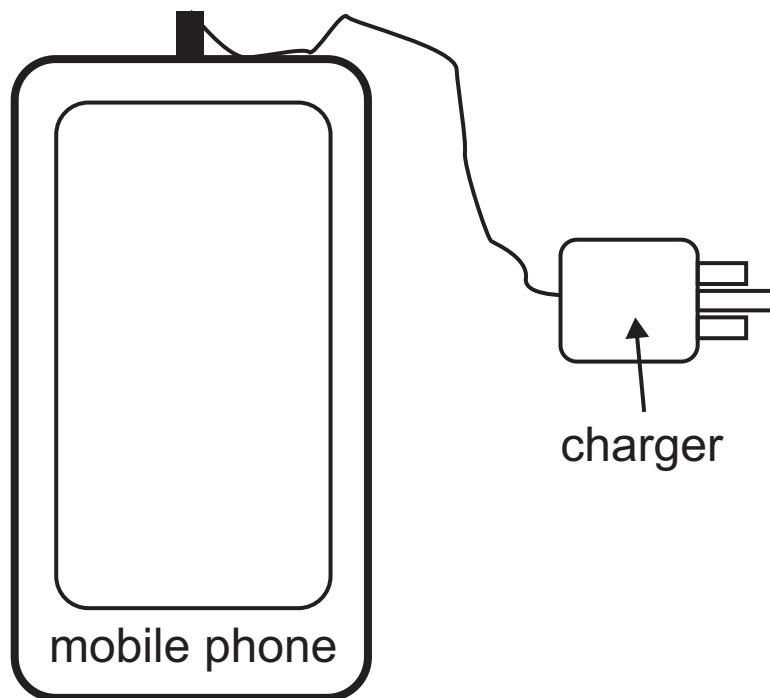

(i) The charger consists of two coils.
The primary coil has 2300 turns of copper wire.
Calculate the number of turns on the secondary coil.
[3 marks]

Show clearly how you get your answer, starting with the equation you plan to use.

Number of turns = _____

Another component in the charger converts 5.0V a.c. to 5.0V d.c. which is used to charge the battery of the mobile phone.

(ii) Describe how a.c. is different from d.c. [2 marks]

a.c. _____

d.c. _____

(c) A coil of wire labelled A B C D is placed between the poles of a magnet as shown below.

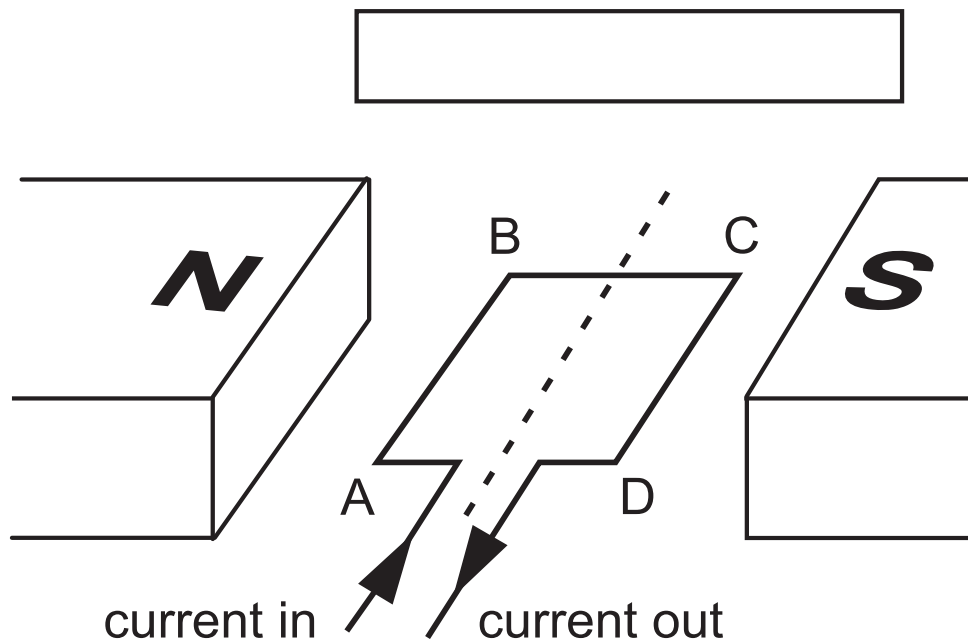

(i) Mark in the box the direction of the magnetic field between the two poles. [1 mark]

(ii) An electric current is passed through the coil of wire in the direction shown.

Circle in the table the directions of the force on the sides AB and CD of the coil. [2 marks]

Side A B	No force	Vertically upwards	Vertically downwards	Horizontally to the right	Horizontally to the left
Side C D	No force	Vertically upwards	Vertically downwards	Horizontally to the right	Horizontally to the left

(iii) What effect do these forces have on the coil of wire? [1 mark]

5 (a) (i) What is meant by a light year? [2 marks]

At one point in its orbit, Earth is at a distance of 4320 million kilometres from Neptune. A radio signal transmitted from a probe at Neptune is directed towards the Earth.

(ii) If radio waves travel in space at a speed of 3×10^8 m/s, how long after transmission will the signal be detected on Earth? [5 marks]

Give your answer in hours.

Show clearly how you get your answer, starting with the equation you plan to use.

Time = _____ hours

(b) (i) What is a galaxy? [1 mark]

(ii) What observation allows astronomers to state that space is expanding? [1 mark]

(c) An astronomer called Edwin Hubble discovered that the speed of many galaxies was directly proportional to their distance from Earth.

This is known as Hubble's Law.

The data below gives information about five galaxies.

Galaxy	Distance/ Billions of light years	Speed/Megametres/ second (Mm/s)
Ursa Major	1.0	15
Corona Borealis	1.4	21
Bootes	2.6	39
Unnamed galaxy	3.0	45
Hydra	4.0	60

- (i) Use the data to plot on the grid opposite a graph of speed (y-axis) against distance (x-axis).
Use \odot or \times to clearly show your plotted points.
Draw the best fit straight line through your points.
[3 marks]

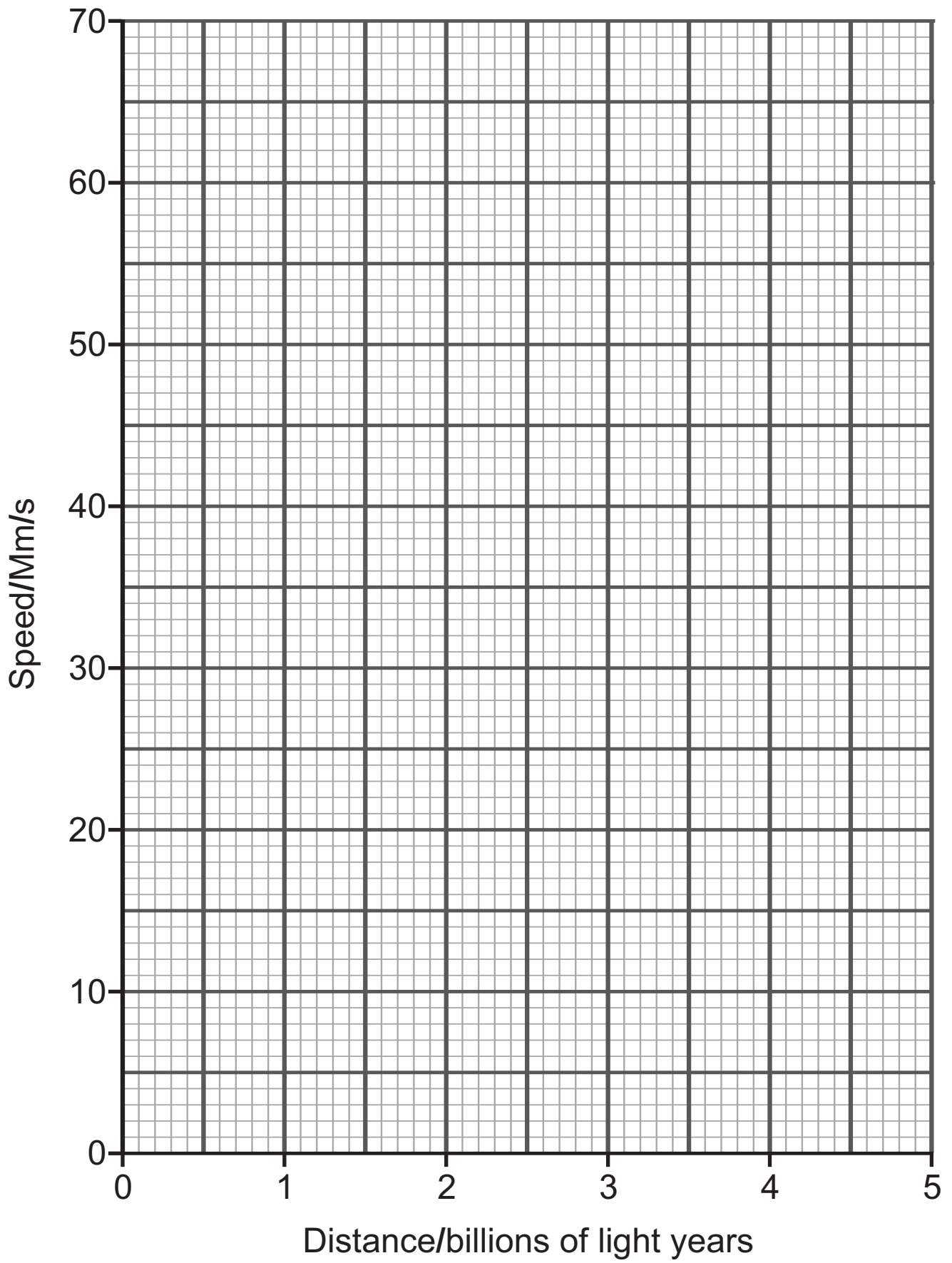

Hubble's Law can be written as

$$v = H_0 d$$

where v is the speed of the galaxy, d is its distance from Earth and H_0 is the Hubble constant.

- (ii) Use your graph to determine the Hubble constant.
[2 marks]
Show clearly how you get your answer.

$$H_0 = \underline{\hspace{15em}}$$

(d) The life cycle of a star the same mass as our Sun is shown below.

However two stages are missing from the diagram. Write the names of the missing stages in the empty boxes. [2 marks]

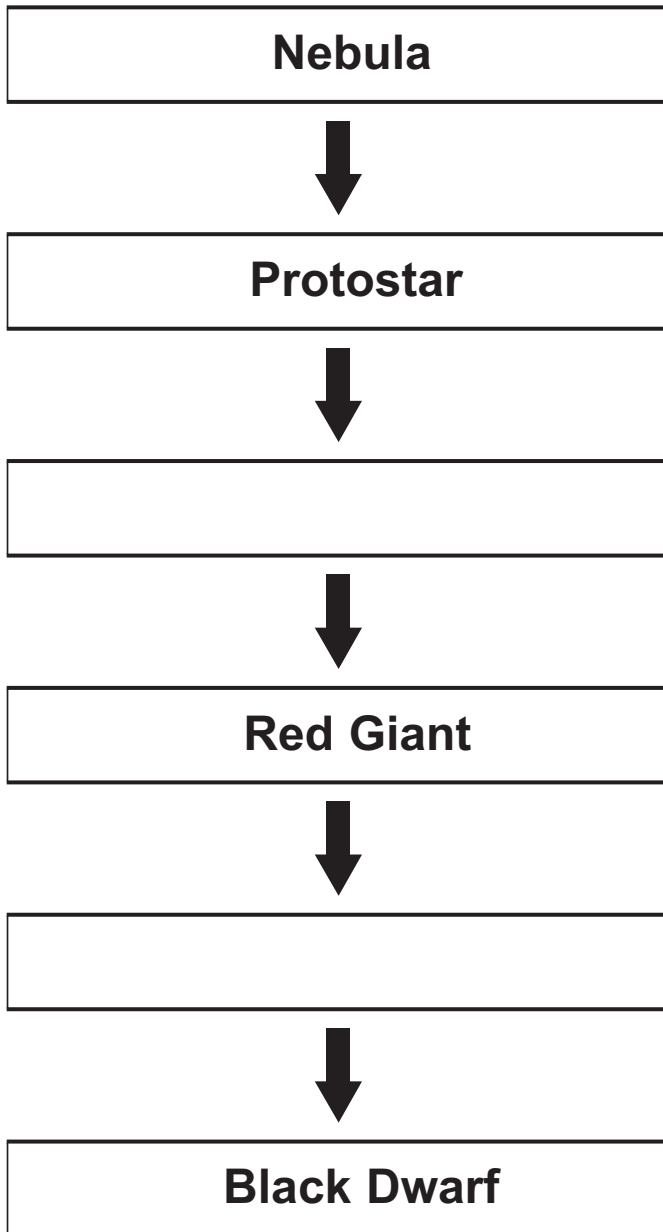

This is the end of the question paper

SOURCES

Q1(c)(i) . Source: © *Chief Examiner*

Q1(c)(iii) . Source: © *Chief Examiner*

Q4(a) . . Source: © *Principal Examiner*

Q4(c) . . Source: © *Principal Examiner*

For Examiner's use only	
Question Number	Marks
1	
2	
3	
4	
5	

Total Marks	
--------------------	--

Examiner Number

Permission to reproduce all copyright material has been applied for.
In some cases, efforts to contact copyright holders may have been unsuccessful and CCEA will be happy to rectify any omissions of acknowledgement in future if notified.